

VIZIO



QUICK START GUIDE

Model: VSB211Z

IMPORTANT SAFETY INFORMATION

Your Sound Bar System is designed and manufactured to operate within defined design limits, and misuse may result in electric shock or fire. To prevent your Sound Bar System from being damaged, the following rules should be observed for its installation, use, and maintenance. Please read the following safety instructions before operating your Sound Bar System. Keep these instructions in a safe place for future reference. Please heed all warnings and follow all instructions.

- To reduce the risk of electric shock or component damage, switch off the power before connecting other components to your Sound Bar System.
- When moving your Sound Bar System from an area of low temperature to an area of high temperature, condensation may form in the housing. Wait before turning on your Sound Bar System to avoid causing fire, electric shock, or component damage.
- Never push any object into the slots and openings on your Sound Bar System enclosure. Do not place any objects on the top of your Sound Bar System. Doing so could short circuit parts causing a fire or electric shock. Never spill liquids on your Sound Bar System.
- Your Sound Bar System should be operated only from the type of power source indicated on the label on the AC/DC Adapters. If you are not sure of the type of power supplied to your home, consult your dealer or local power company.
- Only power of the marked voltage can be used for your Sound Bar System. Any other voltage than the specified voltage may cause fire or electric shock.
- The power cord must be replaced when using different voltage than the voltage specified. For more information, contact your dealer.
- Do not defeat the safety purpose of the grounded plug.
- When connected to a power outlet, power is always flowing into your Sound Bar System. To totally disconnect power, unplug the power cord.

• The lightning flash with arrowhead symbol within an equilateral triangle is intended to alert the user to the presence of un-isolated, dangerous voltage within your Sound Bar System that may be of sufficient magnitude to constitute a risk of electric shock to persons.



• The exclamation point within an equilateral triangle is intended to alert the user to the presence of important operating and servicing instructions in the literature accompanying your Sound Bar System.



- Do not overload power strips and extension cords. Overloading can result in fire or electric shock.
- The wall socket should be located near your Sound Bar System and be easily accessible
- Do not touch the power cord during lightning. To avoid electric shock, avoid handling the power cord during electrical storms.
- Do not attempt to repair or service Sound Bar System yourself. Opening or removing the front cover may expose you to high voltages, electric shock, and other hazards. If repair is required, contact your dealer and refer all servicing to qualified service personnel.
- Keep your Sound Bar System away from moisture. Do not expose your Sound Bar System to rain or moisture. If water penetrates into your Sound Bar System, unplug the power cord and contact your dealer. Continuous use in this case may result in fire or electric shock.
- Do not use your Sound Bar System if any abnormality occurs. If any smoke or odor becomes apparent, unplug the power cord and contact your dealer immediately. Do not try to repair your Sound Bar System yourself.
- Avoid using dropped or damaged appliances. If your Sound Bar System is dropped and the housing is damaged, the internal components may function abnormally. Unplug the power cord immediately and contact your dealer for repair. Continued use of your Sound Bar System may cause fire or electric shock.
- Do not install your Sound Bar System in an area with heavy dust or high humidity. Operating your Sound Bar System in environments with heavy dust or high humidity may cause fire or electric shock.
- Ensure that the power cord and any other cables are unplugged before moving your Sound Bar System.
- When unplugging your Sound Bar System, hold the power plug, not the cord. Pulling on the power cord may damage the wires inside the cord and cause fire or electric shock. When your Sound Bar System will not be used for an extended period of time, unplug the power cord.

- To reduce risk of electric shock, do not touch the connector with wet hands.
- Insert the remote control battery in accordance with instructions. Incorrect polarity may cause the battery to leak which can damage the remote control or injure the operator.
- If any of the following occurs, contact the dealer:
 - The power cord fails or frays
 - Liquid sprays or any object drops into your Sound Bar System
 - Sound Bar System is exposed to rain or other moisture
 - Sound Bar System is dropped or damaged in any way
 - The performance of your Sound Bar System changes substantially
- Keep your Sound Bar System away from moisture. Do not expose your Sound Bar System to rain or moisture. If water penetrates into your Sound Bar System, unplug the power cord and contact your dealer. Continuous use in this case may result in fire or electric shock.
- Unplug the power cord before cleaning your Sound Bar System. Clean only with dry cloth. Do not use a liquid or a spray cleaner on your Sound Bar System. Do not use abrasive cleaners.
- Slots and openings in the back and bottom of the cabinet are provided for ventilation. To ensure reliable operation of your Sound Bar System and to protect it from overheating, be sure these openings are not blocked or covered. Do not place your Sound Bar System in a bookcase or cabinet unless proper ventilation is provided.
- Do not install near any heat sources such as radiators, heat registers, stoves, or other apparatus (including amplifiers) that produce heat.
- Your Sound Bar System AC/DC Adapters are equipped with a three-pronged grounded plug (a plug with a third grounding pin). This plug will fit only into a grounded power outlet. This is a safety feature. If your outlet does not accommodate the three-pronged, have an electrician install the correct outlet, or use an adapter to ground your Sound Bar System safely.
- Protect the power cord from being walked on or pinched particularly at plugs, convenience receptacles, and the point where they exit from the apparatus.
- Only use attachments/accessories specified by the manufacturer.
- Use only with the cart, stand, tripod, bracket, or table specified by the manufacturer, or sold with the apparatus. When a cart is used, use caution when moving the cart/apparatus combination to avoid injury from tip-over.
- Unplug this apparatus during lightning storms or when unused for long periods of time.
- Refer all servicing to qualified service personnel. Servicing is required when the apparatus has been damaged in any way, such as power-supply cord or plug is damaged, liquid has been spilled or objects have fallen into the apparatus, the apparatus has been exposed to rain or moisture, does not operate normally, or has been dropped.
- To reduce the risk of fire or electric shock, do not expose this apparatus to rain or moisture.
- The Apparatus shall not be exposed to dripping or splashing and that no objects filled with liquids, such as vases, shall be placed on the apparatus.
- The main plug is used as the disconnect device, the disconnect device shall remain readily operable.
- CAUTION - Danger of explosion or fire if battery is mistreated. Replace only with the same or specified type.
- Do not leave the battery exposed to direct sunlight for a long period of time with doors and windows closed.
- Do not disassemble the battery or dispose of it in fire.



PACKAGE CONTENTS



32" Home Theater Sound Bar



Power Adapter and Cables



Subwoofer Cable



Stereo RCA to 3.5mm
Audio Cable



This Quick Start Guide



Subwoofer



Remote Control with Battery

Included cables may vary slightly in appearance from those shown.

CONTROLS & CONNECTIONS

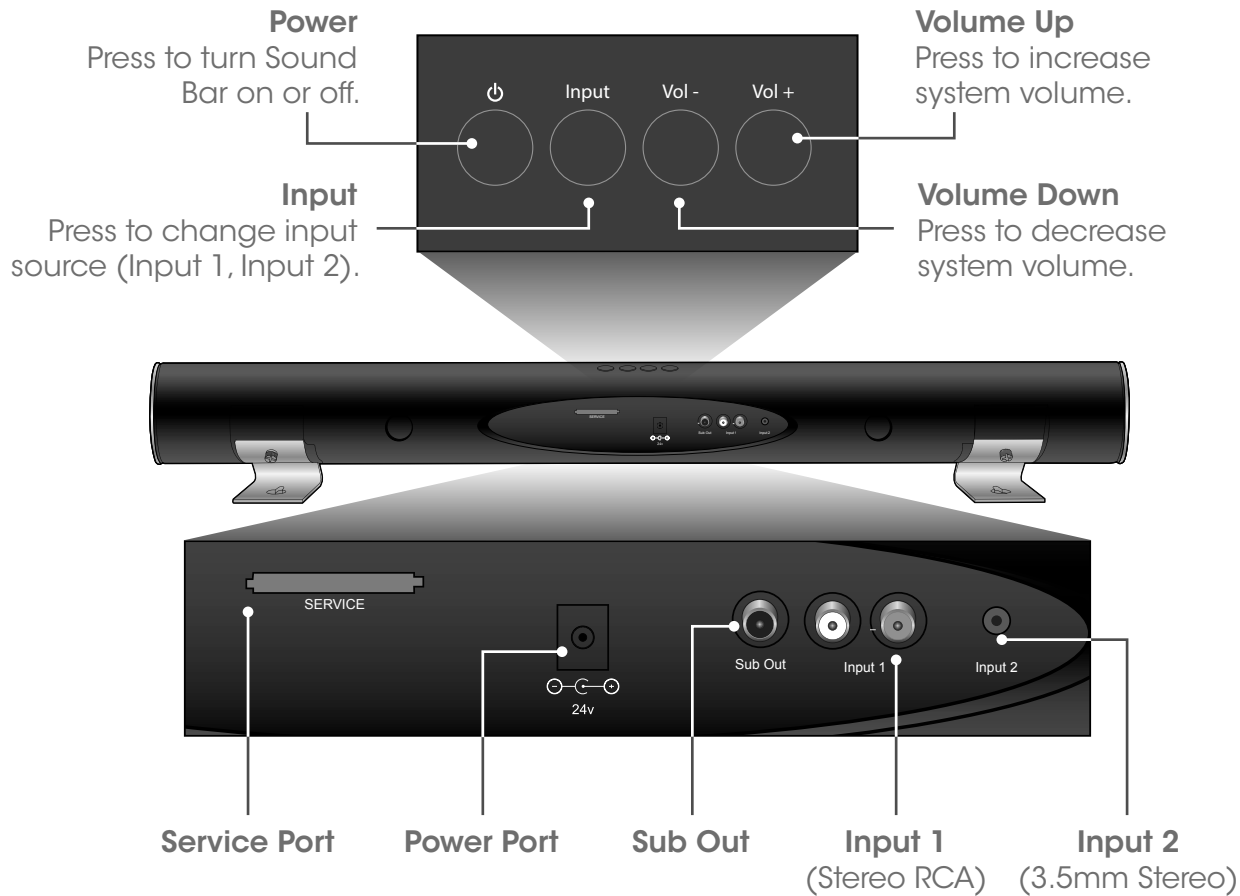

FIRST-TIME SETUP

1



BACK OF YOUR TV *

Connect the included Stereo RCA to 3.5mm Cable to ONE TV audio output as shown.

AUDIO OUT



AUDIO OUT

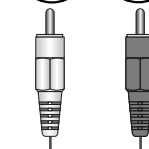
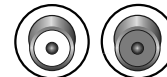

← CHOOSE ONE →

BACK OF SOUND BAR

SERVICE

24v

Sub Out

Input 1

Input 2

*Not all TVs have the audio outputs shown above. To connect the Sound Bar directly to your other devices (Blu-ray player, game system, etc) see your device's user manual.

BACK OF SOUND BAR

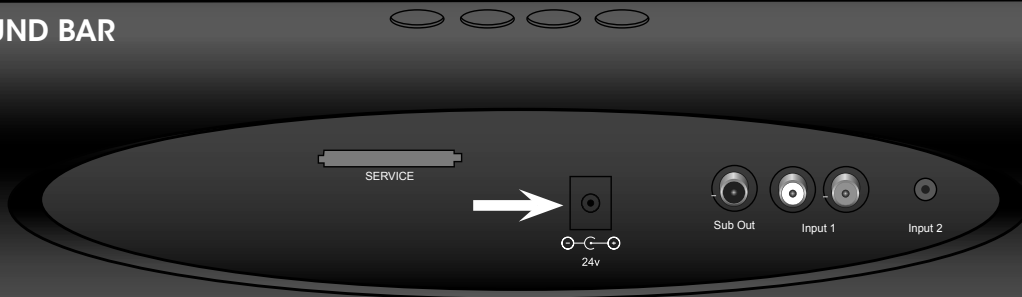

Connect the included power adapter from the sound bar to a power outlet as shown.

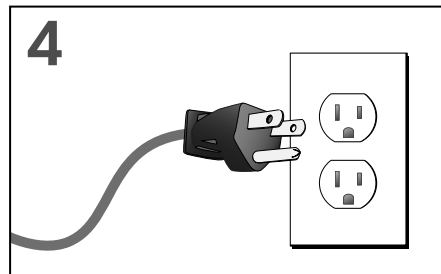
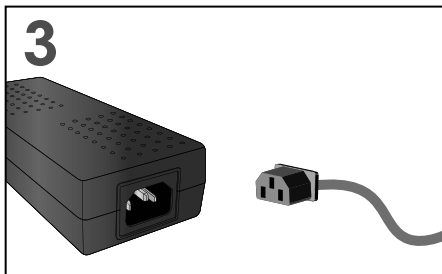
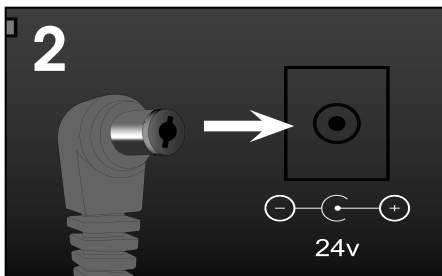



Connect the included Subwoofer Cable from the sound bar to the subwoofer as shown.

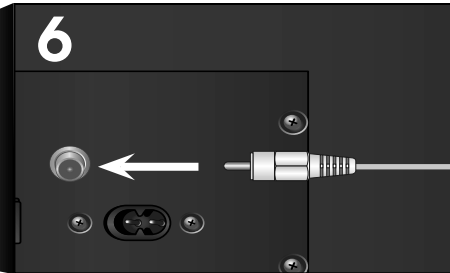
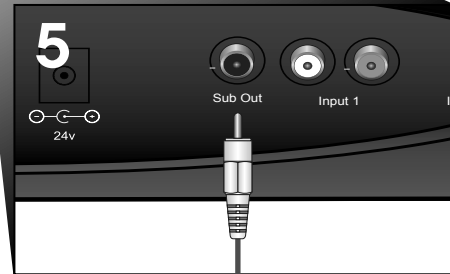

Connect the included power cable from the subwoofer to a power outlet. Then switch the power switch to the **On** position as shown.

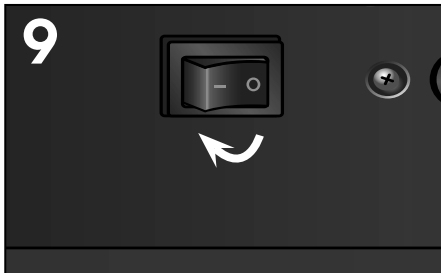
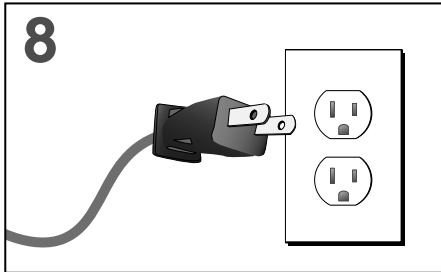
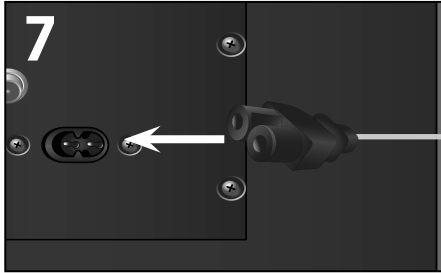

10

Gently pull the plastic tab from the back of the remote control. (The plastic tab can be thrown away.)

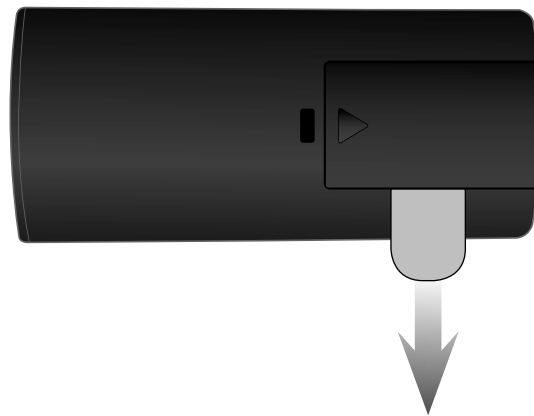

11

Turn your TV on, then press the **Power** button on the remote to turn the Sound Bar on.

Press the **Input** button to switch between the Input 1 and Input 2 audio sources. For example, if you connected your TV to Input 1, set the Sound Bar to Input 1.

Setup is complete.

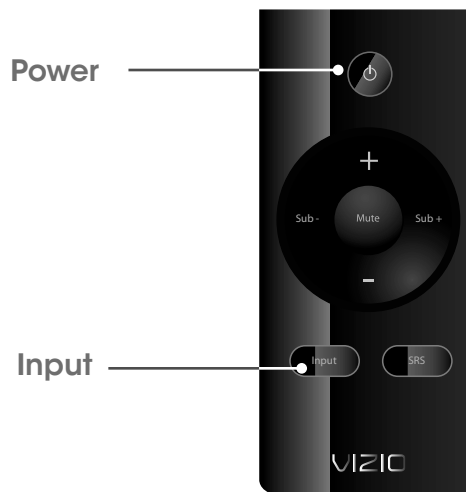

PLACING THE SUBWOOFER

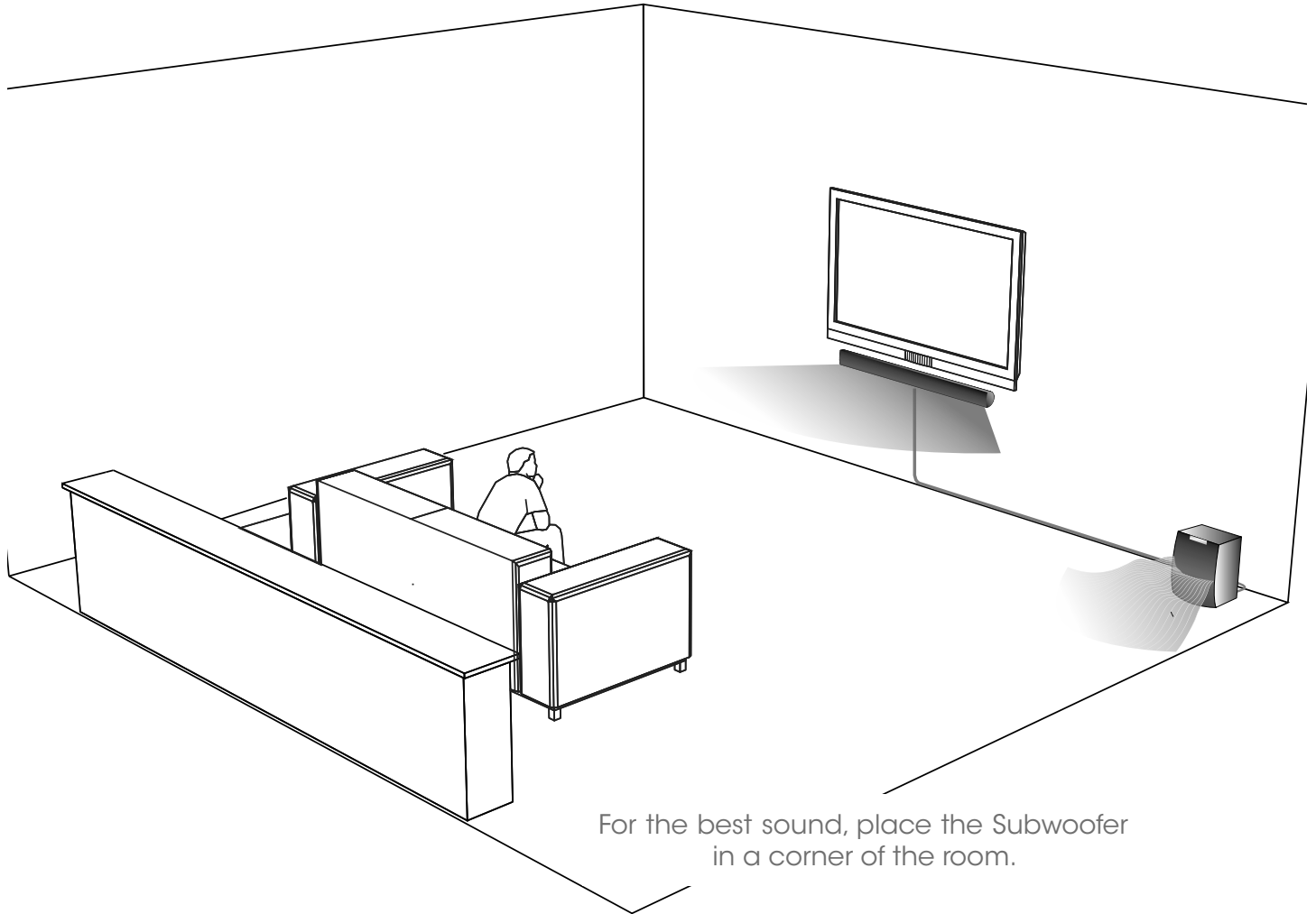

For the best sound, place the Subwoofer
in a corner of the room.

WALL MOUNTING THE SOUND BAR

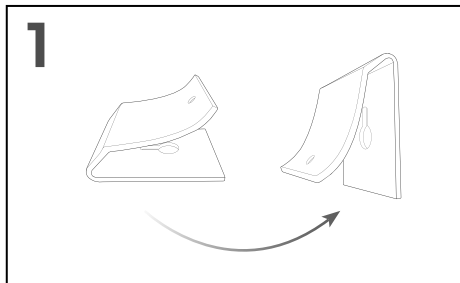

Remove the screw from the Sound Bar stands and rotate as shown.

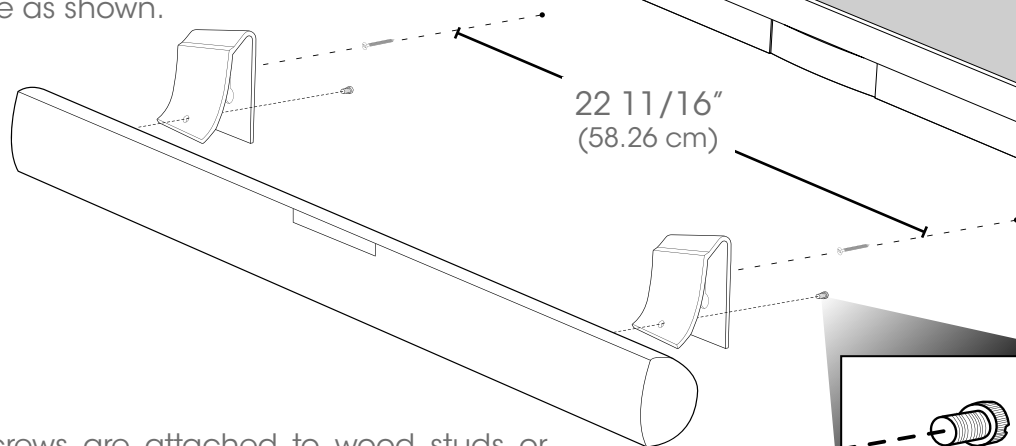

2

Be sure your screws are attached to wood studs or drywall anchors (for drywall) or concrete anchors (for brick/concrete walls).



If you are unfamiliar with power tools or the layout of electrical wiring in the walls of your home, consult a professional installer.

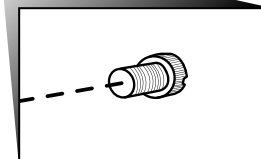

Reattach stands using the included screw.

USING THE REMOTE

SUB -
Press to decrease subwoofer volume.

Volume Down
Press to decrease volume.

Input
Press to change input source.

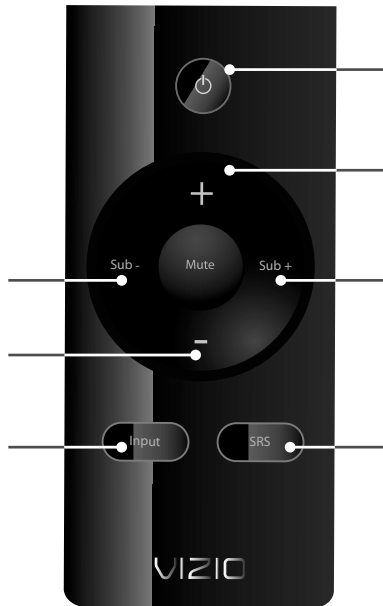

Power
Press to turn on or off.

Volume Up
Press to increase volume.

SUB +
Press to increase subwoofer volume.

SRS On/Off
Press to turn SRS WOW HD on.

When SRS WOW HD is activated, the orange light on the front of the Sound Bar is on.

SRS WOW HD improves audio performance by expanding the audio image, resulting in deep, rich bass and added clarity.

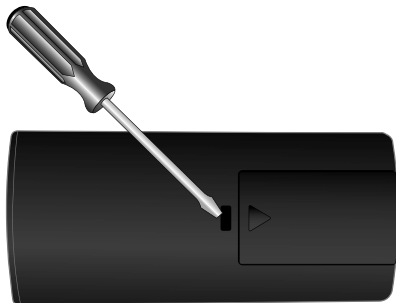

If your remote stops responding, you may need to replace the battery.

To replace the battery, insert a flat-head screwdriver into the slot as shown. Gently push down on the tab, then press and pull downward on the battery cover to open.

DO YOU HAVE QUESTIONS?
LET US HELP!

YOUR PRODUCT INCLUDES FREE LIFETIME TECH SUPPORT

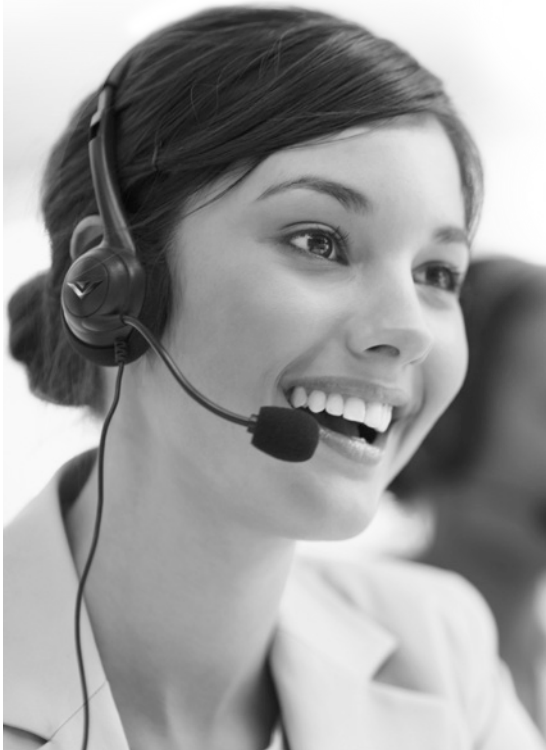

The VIZIO support team is highly trained and is based in the United States.

We can help with:

- New Product Setup
- Connecting Your Devices
- Technical Problems
- And More

Phone: (877) 878-4946 (TOLL-FREE)

Email: techsupport@VIZIO.com

Web: www.VIZIO.com/support

Hours of operation:

Monday - Friday: 5 AM TO 9 PM (PST)

Saturday - Sunday: 8 AM TO 4 PM (PST)

We speak English • Se habla Español • Nous parlons Français

HELP & TROUBLESHOOTING

There is no power.

- Press the **POWER** button on the remote control or on the top of your Sound Bar.
- Ensure the power cord is securely connected.
- Ensure the light on the power adapter is glowing green.
- Plug a different device into the electrical outlet to verify that the outlet is working correctly.

There is no sound.

- Increase the volume. Press **Volume Up** on the remote control or on the top of your Sound Bar.
- Press **MUTE** on the remote to ensure the Sound Bar is not muted.
- Press **INPUT** on the remote or on the top of your Sound Bar to select a different input source.
- If you are using the 3.5mm output from your TV, be sure that is connected to an audio **OUTPUT** and not audio **INPUT**. Some TVs use 3.5mm audio **INPUT** for devices such as computers.
- Your TV may be set to variable audio output. Confirm that the audio output setting is set to **FIXED** or **STANDARD**, not **VARIABLE**. Consult your TV's user manual for more detailed information.

I hear buzzing or humming.

- Ensure all cables and wires are securely connected.
- Connect a different source device (TV, Blu-ray player, etc) to see if the buzzing persists. If it does not, the problem may be with the original device.
- Connect your device to a different input on the Sound Bar.

There is no bass.

- Press the **SUB +** button on the remote control to increase the bass level.
- Ensure the subwoofer cable is securely connected to the Subwoofer and to the Sound Bar.
- Ensure the subwoofer is plugged in and the power switch is in the **On** position.

There is too much bass.

- Press the **SUB -** button on the remote control to decrease the bass level.

ONE-YEAR LIMITED WARRANTY

ON PARTS AND LABOR

Covers units purchased as new in United States and Puerto Rico Only

VIZIO provides a warranty to the original purchaser of a new Product against defects in materials and workmanship for a period of one year of non-commercial usage and ninety (90) days of commercial use. If a Product covered by this warranty is determined to be defective within the warranty period, VIZIO will either repair or replace the Product at its sole option and discretion.

To obtain warranty service, contact VIZIO Technical Support via email: TechSupport@VIZIO.com or via phone at 877 MY VIZIO (877.698.4946) from 6:00AM to 9:00PM Monday through Friday and 8:00AM to 4:00PM Saturday and Sunday, Pacific Time, or visit www.VIZIO.com. PRE-AUTHORIZATION MUST BE OBTAINED BEFORE SENDING ANY PRODUCT TO A VIZIO SERVICE CENTER. Proof of purchase in the form of a purchase receipt or copy thereof is required to show that a Product is within the warranty period.

Parts and Labor

There will be no charge for parts or labor during the warranty period. Replacement parts and Products may be new or recertified at VIZIO's option and sole discretion. Replacement parts and Products are warranted for the remaining portion of the original warranty or for ninety (90) days from warranty service or replacement, whichever is greater.

Type of Service

Defective Products must be sent to a VIZIO service center to obtain warranty service. VIZIO is not responsible for transportation costs to the service center, but VIZIO will cover return shipping to the customer. PRE-AUTHORIZATION IS REQUIRED BEFORE SENDING ANY PRODUCT TO A VIZIO SERVICE CENTER FOR WARRANTY SERVICE.

Product returns to VIZIO's service centers must utilize either the original carton box and shipping material or packaging that affords an equal degree of protection. VIZIO Technical Support will provide instructions for packing and shipping the covered Product to the VIZIO service center.

Limitations and Exclusions

VIZIO's one-year limited warranty only covers defects in materials and workmanship. This warranty does not cover, for example: cosmetic damage, normal wear and tear, improper operation, improper voltage supply or power surges, signal issues, damages from shipping, acts of God, any type of customer misuse, modifications or adjustments, as well as installation and set-up issues or any repairs attempted by anyone other than by a VIZIO authorized service center. Products with unreadable or removed serial numbers, or requiring routine maintenance are not covered. This one year limited warranty does not cover Products sold "AS IS", "FACTORY RECERTIFIED", or by a non-authorized reseller.

THERE ARE NO EXPRESS WARRANTIES OTHER THAN THOSE LISTED OR DESCRIBED ABOVE. ANY IMPLIED WARRANTIES, INCLUDING ANY IMPLIED WARRANTY OF MERCHANTABILITY AND FITNESS FOR A PARTICULAR PURPOSE, SHALL BE LIMITED IN DURATION TO THE PERIOD OF TIME SET FORTH ABOVE. VIZIO'S TOTAL LIABILITY FOR ANY AND ALL LOSSES AND DAMAGES RESULTING FROM ANY CAUSE WHATSOEVER INCLUDING VIZIO'S NEGLIGENCE, ALLEGED DAMAGE, OR DEFECTIVE GOODS, WHETHER SUCH DEFECTS ARE DISCOVERABLE OR LATENT, SHALL IN NO EVENT EXCEED THE PURCHASE PRICE OF THE PRODUCT. VIZIO SHALL NOT BE RESPONSIBLE FOR LOSS OF USE, LOSS OF INFORMATION OR DATA, COMMERCIAL LOSS, LOST REVENUE OR LOST PROFITS, OR OTHER INCIDENTAL OR CONSEQUENTIAL DAMAGES. SOME STATES DO NOT ALLOW LIMITATIONS ON HOW LONG AN IMPLIED WARRANTY LASTS OR THE EXCLUSION OF INCIDENTAL OR CONSEQUENTIAL DAMAGES, SO THE ABOVE LIMITATIONS OR EXCLUSIONS MAY NOT APPLY TO YOU. THIS WARRANTY GIVES YOU SPECIFIC LEGAL RIGHTS, AND YOU MAY ALSO HAVE OTHER RIGHTS, WHICH VARY FROM STATE TO STATE. THIS WARRANTY IS SUBJECT TO CHANGE WITHOUT NOTICE. CHECK www.VIZIO.com FOR THE MOST CURRENT VERSION.

SPECIFICATIONS

Sound Bar: Two 2.75" High-Efficiency Hand-Built Full Range Transducers

Inputs: 1 x 3.5mm Audio
1 x RCA Stereo Audio

Outputs: 1 x RCA Sub Out

Sound Pressure Level: 90 dB

Frequency Response: 90Hz - 19 KHz

Voltage: 100-240 VAC, 50-60 Hz

Dimensions 31.50" x 4.00" x 3.65" (with stand)
(Sound Bar): 31.50" x 3.25" x 3.65" (w/o stand)

Dimensions
(Subwoofer): 8.13" x 10.50" x 9.56"

LEGAL & COMPLIANCE

FCC Class B Radio Interference Statement

NOTE: This equipment has been tested and found to comply with the limits for a Class B digital device, pursuant to Part 15 of the FCC Rules. These limits are designed to provide reasonable protection against harmful interference in a residential installation. This equipment generates, uses and can radiate radio frequency energy, and if not installed and used in accordance with the instructions, may cause harmful interference to radio communications. However, there is no guarantee that interference will not occur in a particular installation. If this equipment does cause harmful interference to radio or television reception, which can be determined by turning the equipment off and on, the user is encouraged to try to correct the interference by one or more of the following measures:

1. Reorient or relocate the receiving antenna.
2. Increase the separation between the equipment and receiver.
3. Connect the equipment into an outlet on a circuit different from that to which the receiver is connected.
4. Consult the dealer or an experienced radio/TV technician for help.

This device complies with Part 15 of the FCC Rules. Operation is subject to the following two conditions: (1) this device may not cause harmful interference, and (2) this device must accept any interference received, including interference that may cause undesired operation.

Notice:

1. The changes or modifications not expressly approved by the party responsible for compliance could void the user's authority to operate the equipment.
2. Shielded interface cables and AC power cord, if any, must be used in order to comply with the emission limits.
3. The manufacturer is not responsible for any radio or TV interference caused by unauthorized modification to this equipment. It is the responsibilities of the user to correct such interference.

RF Exposure Information

This device meets the government's requirements for exposure to radio waves. This device is designed and manufactured not to exceed the emission limits for exposure to radio frequency (RF) energy set by the Federal Communications Commission of the U.S. Government. This device complies with FCC radiation exposure limits set forth for an uncontrolled environment.

IC Statement

Operation is subject to the following two conditions:

1. This device may not cause interference, and
2. This device must accept any interference, including interference that may cause undesired operation of the device.

This Class B digital apparatus complies with Canadian ICES-003.

Cet appareil numérique de la classe B est conforme à la norme NMB-003 du Canada.

IC Radiation Exposure Statement

This equipment complies with IC RSS-102 radiation exposure limits set forth for an uncontrolled environment. This equipment should be installed and operated with minimum distance 20cm between the radiator & your body.

Disposal and Recycling

You must dispose of this product properly, according to local laws and regulations. Because this product contains electronic components and a battery, it must be disposed of separately from household waste. Contact local authorities to learn about disposal and recycling options.



This product qualifies for ENERGY STAR in the "factory default" setting and this is the setting in which power savings will be achieved. Changing the factory default settings or enabling other features will increase power consumption that could exceed the limits necessary to qualify for ENERGY STAR rating.



Incorporated under license from SRS Labs, Inc.
SRS WOW HD is a trademark of SRS Labs, Inc.

VIZIO RECOMMENDS



The VIZIO Co-Star™ Stream Player merges live TV and streaming entertainment into one experience, turning any HDTV into the ultimate smart TV. Using the latest version of Google TV™, Co-Star decks out your existing HDTV with apps, full-screen Web browsing and the best in streaming entertainment. And with 1080p Full HD resolution, built-in Wi-Fi, and 3D-readiness, VIZIO Co-Star is the ultimate entertainment upgrade for any high-definition television.

Available at www.VIZIO.com

This Product Sold Separately



M GO movies & TV

vudu 100 Movies

PANDORA

NETFLIX

huluPLUS

YouTube

amazon instant video

VIZIO RECOMMENDS

M-Series Razor LED™ Smart TV

The all-new VIZIO M-Series Razor LED™ Smart TV with Theater 3D® has arrived. With an ultra-modern design, brilliant Razor LED™ picture quality, and the new, faster VIZIO Internet Apps Plus™ Smart TV experience, it's the must-have entertainment upgrade you've been waiting for.

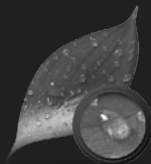

Razor-LED Brilliance



Faster Smart TV



Signature Design

Available at VIZIO.com

product sold separately

